



KYTS Coolant Temperature Sensor for Diesel Engine

Description:

The thermistor in front of the sensor probe is affected by the temperature. The change of resistance (variation of the temperature coefficient is negative), into electrical signal output by the conversion circuit, which characterizes the measured temperature value.

Application:

- Coolant temperature measurement
- Monitoring the gas temperature
- The water temperature detection
- Transmission oil temperature measurement

Features:

- ◆ Agile response
- ◆ High reliability, high recovery
- ◆ Wide working temperature range
- ◆ Waterproof and dustproof
- ◆ High strength copper alloy structure
- ◆ Good site interchangeability
- ◆ Anti lost gasket

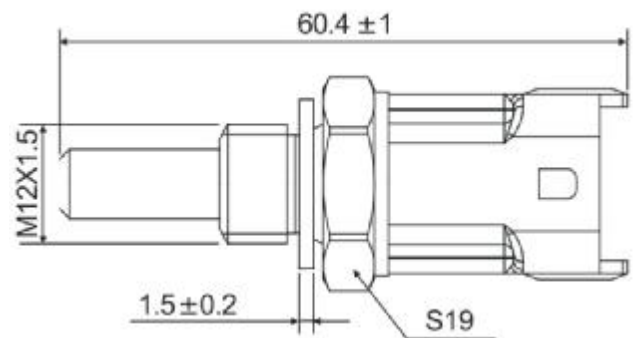

Specifications:

Parameter	Value	Units
Constant current power supply current	≤ 1	mA
Thread interface	M12×1.5	--
Measurement of medium	Gas or liquid compatible with H62	--
Work temperature	-40~125	°C
Storage Temperature	-40~130	°C
Error in normal temperature(20 °C)	± 2	°C
Error in high temperature(100 °C)	± 1	°C
Temperature response time (T63)	≤ 15	S
Output Voltage	Resistance; the output can be customized 0.5~4.5V or 4~20mA	--



Application Description:

This product is suitable for measuring the engine Coolant temperature, engine intake temperature and transmission oil temperature to realize the function temperature alarm and control.

Outer packing size: 22.4*16.5*10cm

Xinhui KangYu Control Systems Engineering, Inc.

Guifeng Hightech Village, Ximen Rd., Xinhui District, Jiangmen City, Guangdong 529100, P.R. China

Tel: 86-750-6318857 Fax: 86-750-6318900 E-mail: sale@chinakangyu.com Website: www.chinakangyu.com